



Twin-Temp Thermometer

Twin-Temp Transmitting Accessories and Options

Type TT.52

Thermometers

Application

Industrial type design for fluid medium which does not corrode 304 stainless steel. Designed for applications requiring local readability using a mechanical measuring element while affording an additional means of electronic data acquisition from the same instrument.

Sizes

5" (127 mm) - Type TT.52

Accuracy

+ 1.0% of measurement range

Ranges

-40 °F to 550 °F (and equivalent Celcius)

Over/Under Range Protection

Temporary over or under range of 50% (maximum exposure 500 °F)

Standard Features

Connection

Material: 304 stainless steel
All angle - Type TT.52
1/2" NPT standard

Stem

Material: 304 stainless steel
Diameter: 1/4" (6.35 mm)
Length: 2 1/2" to 48" (63.5 mm to 1,219.2 mm)

Measuring Element (Mechanical)

Bi-metal helix

Measuring Element (Electrical)

Thermocouple

Type K Grounded Junction Thermocouple standard
(Type J, E, and T available)

RTD

Platinum 100-ohm, DIN curve (0.00385 Ohm/Ohm/°C)
(3 wire standard configuration)

Case

Material: 304 stainless steel
Hermetically sealed per ASME B40.3 standard
External reset slotted hex head on back of case

Dial

White aluminum, dished, with black markings

Pointer

Black aluminum

Standard Scales

Single: Fahrenheit or Celsius
Dual: Fahrenheit (outer) and Celsius (inner)



Window

Flat instrument glass

Order Options

Weather-proof Housing and Plug

7/8-20 UNEF threaded barrel with busing and compression nut. Provides environmental protection to thermocouple/RTD connection.

Electrical Connection With Lead Wire (1/2 NPT)

Available in thermocouple or RTD in 6" increments. Allows site installation using other enclosures or piping systems.

Thermocouple Enclosure Head

A protective enclosure threads onto the optional 1/2 NPT electrical connection. The housing protects electrical connections from the environment. Houses a 4-20 mA transmitter or terminal block. Aluminum housing is standard.

Terminal Block

Provides a connection point for the thermocouple or RTD. Mounts in thermocouple head with 2 screws.

4-20 mA Transmitter

Refer to transmitter specifications

Additional Options

Thermowells
Acrylic, Lexan, and safety glass window
Calibration certification traceable to NIST

Warranty

Limited one year warranty as stated in WIKAI's Terms & Conditions of Sale

Dimensions:

Twin-Temp Thermometer

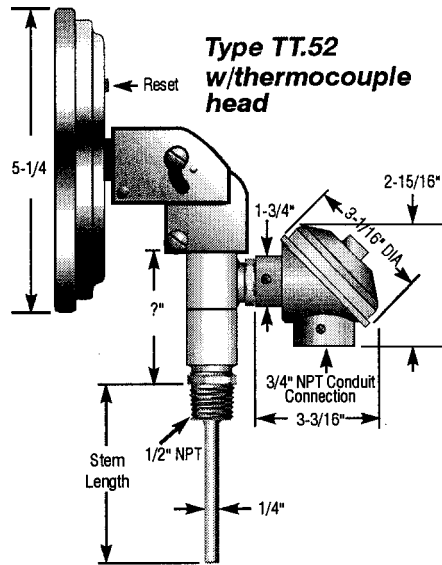

Thermocouple
Enclosure couple
connection is 1/2" NPT.
Must specify "Lead
Wire" connection with
thermocouple
enclosure head.

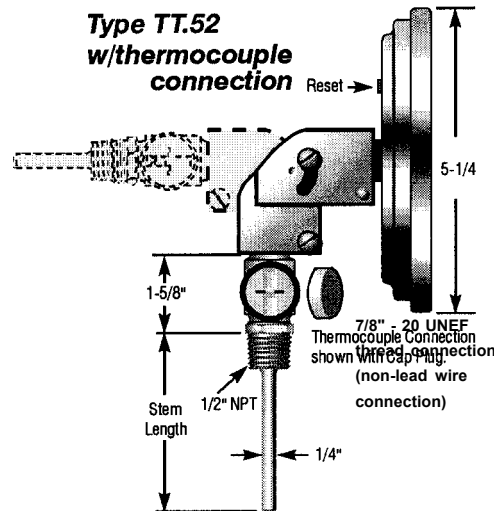

i D T R t e o n) n n o w c o h

THE MEASURE OF
Total Performance™

Ordering Information:

State computer part number (if available) / type number / size / range / connection size and location / options required.

Specifications given in this price list represent the state of engineering at the time of printing. Modifications may take place and the specified materials may change without prior notice

ATM
05/02



www.wika.ws

Distributed By **FLW** Inc,

(800) 576-6308